

TRAM

INSTALLATION INSTRUCTIONS | JULY 2020

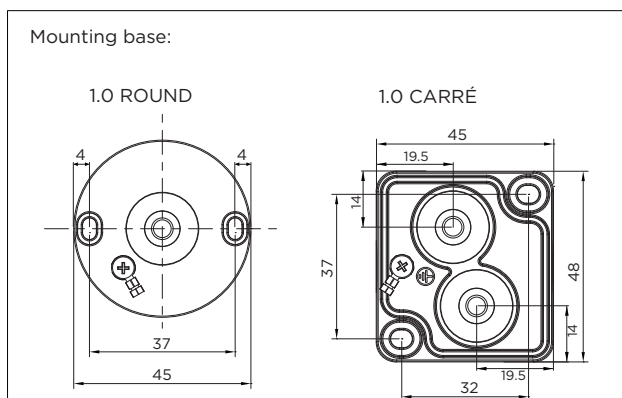

DIMENSIONS

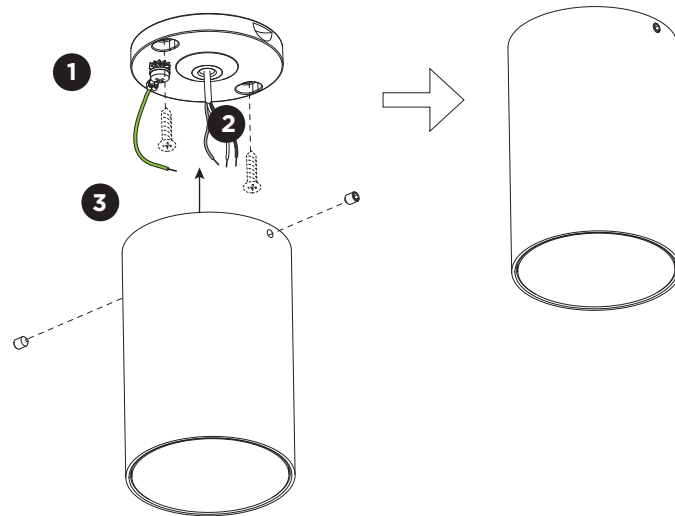

1.0 ROUND

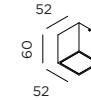

1.0 CARRÉ

1 Remove the mounting base from the luminaire by loosening the socket screws and mount it on the ceiling with screws (screws are not included).

2 POWER CONNECTION

Connect to 220-240V.

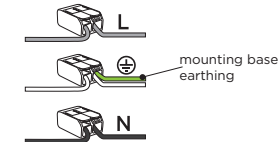

Connect the earth cable.

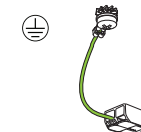

Please use a matching grommet based on the used 220-240V cable and the corresponding type in the overview table.

	A	B	C	D
use pin to make hole, not a knife				
CABLE				
TYPE	ROUND H05RN-F H07RN8-F H07RN-F	ROUND H05RN-F	ROUND	ROUND
OUTSIDE Ø	min 6.8mm max 8.9mm	min 5mm max 6.8mm	min 1.5mm max 2.6mm	min 1.5mm max 2.6mm
CONDUCTION SECTION	2or3x 0.75mm ² 2or3x 1.0mm ² 2or3x 1.5mm ²	2or3x 0.75mm ² 2x 1.0mm ²	0.75mm ² 1.5mm ²	0.75mm ² 1.5mm ²

3 Fixate the luminaire on the base with the socket screws.